

Quantum computational complexity in the presence of closed timelike curves

Dave Bacon*

*Institute for Quantum Information, California Institute of Technology, Pasadena, California 91125, USA
and Department of Physics, California Institute of Technology, Pasadena, California 91125, USA*

(Received 28 October 2003; published 13 September 2004)

Quantum computation with quantum data that can traverse closed timelike curves represents a new physical model of computation. We argue that a model of quantum computation in the presence of closed timelike curves can be formulated which represents a valid quantification of resources given the ability to construct compact regions of closed timelike curves. The notion of self-consistent evolution for quantum computers whose components follow closed timelike curves, as pointed out by Deutsch [Phys. Rev. D **44**, 3197 (1991)], implies that the evolution of the chronology respecting components which interact with the closed timelike curve components is nonlinear. We demonstrate that this nonlinearity can be used to efficiently solve computational problems which are generally thought to be intractable. In particular we demonstrate that a quantum computer which has access to closed timelike curve qubits can solve NP -complete problems with only a polynomial number of quantum gates.

DOI: 10.1103/PhysRevA.70.032309

PACS number(s): 03.67.Lx, 04.20.Gz

I. INTRODUCTION

The idea that *information is physical* has given rise to a series of discoveries which indicate that physics has much to say about the foundations of computer science. Computers which exploit coherent quantum evolution remarkably offer computational speedups over computers which evolve classically [1,2]. This discovery has led to the development of a robust theory of computation with quantum elements: the theory of quantum computation [3]. Current theoretical work [4–9] indicates that there is no fundamental physical obstacle toward the construction of a working quantum computer. The laws of physics appear to allow for quantum computation.

The realization that the physicality of information has a profound effect on fundamental computer science challenges physics to understand the computational power of different physical theories. In this article we present an analysis of the consequences of one such theory. Morris, Thorne, and Yurtsever [10] asked the question of whether the laws of physics allow for the construction and maintenance of stable wormholes. The construction of such wormholes would necessarily lead to spacetimes with closed timelike curves (CTC's) [11]. Without a theory of quantum gravity, however, there has been no conclusive resolution of the question of whether nature allows for CTC's [11–14]. Despite this uncertainty, various authors have attempted to ascertain the status of the initial value problem on spacetimes with CTC's [15–23]. Of particular importance in this initial value problem is the notion of self-consistent evolution [15,16]. Previous arguments against the existence of CTC's which dictated that CTC's will always lead to paradoxical evolution [24] now appear to be unfounded, especially in the context of quantum theory [16,18]. For a given specification of initial data, there is always a self-consistent evolution of these data which does not

give rise to any of the typical “patricidal paradoxes” usually associated with time travel.

In this article we examine the consequences of quantum computation in the presence of closed timelike curves. This work is complementary to work done by Brun [25] who demonstrated that a model of classical computation in the presence of CTC's could be used to solve hard computational problems in constant time. However, the world is not classical, and the status of the classical initial value problem in the presence of CTC's has no known generic solution [15]. Thus in Brun's model of computation, it is explicitly possible to write down programs which have no self-consistent evolution. Diverging from Brun's approach we follow the formalism of Deutsch [16] who, soon after helping develop the theory of quantum computation, applied this formalism to the question of computation in the presence of CTC's. Deutsch was able to show that quantum computation in the presence of CTC's always allows self-consistent evolution. The evolution of chronology respecting systems interacting with systems which traverse CTC's, while locally unitary, Deutsch showed, is globally nonlinear. Nonlinearity in quantum computation has been shown by Abrams and Lloyd [26] to be a powerful tool for solving hard computational problems. Both Deutsch and Brun conjectured that quantum computation in the presence of CTC's could solve hard problems. Here we show that this is indeed correct by demonstrating that the nonlinearity allowed by quantum computation in the presence of CTC's can be used to efficiently solve classically hard computational problems. We present specific cases of quantum evolution near CTC's which can be used to efficiently solve NP -complete problems. The efficient solution of such problems (the $P=NP$ question) has long been doubted in classical computational complexity and it is also believed that quantum computers alone do not efficiently solve these important computer science problems. If nature allows for CTC's, then the theory of quantum computation in the presence of such CTC's provides for the efficient solution of computational problems previously thought to be intrac-

*Electronic address: dabacon@cs.caltech.edu

table and therefore represents one of the most powerful physical models of computation known.

Given the extraordinary power of quantum computation in the presence of CTC's, however, one may wonder whether, as is the case with the similarly powerful models of analog computation [27], this result is robust in the presence of noise or whether noise destroys the effect we are exploiting to solve the hard problem.¹ This is particularly worrisome because we use nonlinear evolution to achieve an exponential increase in the distinguishability of two nearly identical quantum systems: what is to keep the noise from growing exponentially along with this distinguishability? We show, however, that the traditional methods of fault-tolerant quantum computation can be used to overcome at least some of the problems raised in this context. Thus, to the extent that the error mechanisms we consider encompass realistic errors for the model of quantum computation in the presence of CTC's, we find that a robust model of computation in the presence of CTC's can be formulated.

II. QUANTUM COMPLEXITY THEORY WITH CLOSED TIMELIKE CURVES

In physics, determination of the *allowable* manipulations of a physical system is of central importance. Computer science, on the other hand, has arisen in order to *quantify* what resources are needed in order to perform a certain algorithmic task. When one examines the computational consequences of a fundamental physical theory it is important that computer science's quantification represent a reasonable application of physical resources. One such quantification of physical resources for a quantum computer is given by the quantum circuit model [28]. In the quantum circuit model, a series of gates are applied to a collection of qubits which have been prepared in an input state and are then measured to obtain the computation's output. In order to be a realistic model of computation, it is usually assumed that there is some notion of locality among the quantum gates and further that these gates are generated by few-qubit interactions. The quantification of a quantum circuit model is then classified by the manner in which the quantum gates are used. There are various measures of complexity within this model which can be used: one can use the total number of gates, the depth of the circuit, or the breadth of the circuit. That this is a good quantification of resources has been argued elsewhere [28].

In order to deal with CTC's within the quantum circuit model, we make the simplifying assumptions enumerated by Deutsch [16] and Politzer [21]: (a) The region of CTC's is a compact region of spacetime whose existence is generated by evolution from initial conditions prior to this compact region. (b) Two types of qubits in the quantum circuit model can be identified: those which traverse CTC's and those which do not. (c) Unitary evolution between the CTC qubits and the chronology respecting qubits is allowed. (d) Measurement and preparation of the CTC qubits is not allowed (see below however). (e) The evolution of the CTC qubits is determined by self-consistency. Deutsch [16] has argued that quantum

computation in the presence of spacetimes which possess unambiguous pasts and unambiguous futures which are chronology respecting can always be mapped onto the simplified model described by conditions (a)–(e). In particular there are a large class of spacetimes for which, by a suitable mapping of the quantum network [16], can be mapped into the above model: the model does not apply to simply the spacetimes described by, say, Politzer in [20]. This being said, it should be kept in mind that there are situations where the above conditions are too indeed too strict (especially for spacetimes with cosmological CTC's [14]).

Quantification of resources in this modified quantum circuit model then follows the same lines of reasoning as in the unmodified version. Now, however, gates between all qubits (CTC qubits and chronology respecting qubits) should be used in the quantification. It should be noted that in this model, the CTC qubits are a resource which cannot be reused: they are an expendable resource. Further, it is assumed that the resource cost of creating n CTC qubits is not exponential in n .

Finally, note that this quantification of resources implies that the naive method of using a CTC to perform a computation over and over again until the answer is arrived at is not quantified as a tractable use of resources. One could solve a hard problem by trying out a solution to the problem, sending one's computer back in time, attempting a different solution to the problem, sending one's computer back and time, etc., until a solution to the problem has been found. Each time we send the computer back in time, we will have another copy of the computer in existence: the computer is in no way being reused. While only a single wormhole could be used for such an experiment and the total time required to obtain a solution will be constant, the number of computers (i.e., spatial resources) which need to exist to carry out this naive method is exponential in the problem size (when one sends a computer back in time, the previous versions of the computer still exist and in the worse case scenarios this number of computers is intractable in the problem size.) The goal of this paper is to show that a better alternative to the naive approach can actually be used to solve hard computational problems.

III. SELF-CONSISTENT QUANTUM EVOLUTION

Consider a system of n qubits, $n-l$ of which are qubits which evolve along chronology respecting world lines and l of which evolve along CTCs (see Fig. 1). The Hilbert space of these qubits is given by the tensor product $\mathcal{H} \equiv \mathcal{H}_A \otimes \mathcal{H}_B$ where \mathcal{H}_A represents the chronology respecting qubits and \mathcal{H}_B represents the qubits which traverse CTC's. Input into the quantum circuit comes from the initial conditions of the chronology respecting qubits. We now make two assumptions whose validity we discuss below: (a) There is a temporal origin of the CTC's which can be identified via the first interaction with the chronology respecting qubits. (b) The initial state of the chronology respecting and CTC qubits is initially uncorrelated. Let U be the unitary evolution operator of the entire system (made up of a series of gates), ρ_{in} be the density matrix of the chronology respecting qubits, and ρ be

¹This point was first brought to our attention by Patrick Hayden.

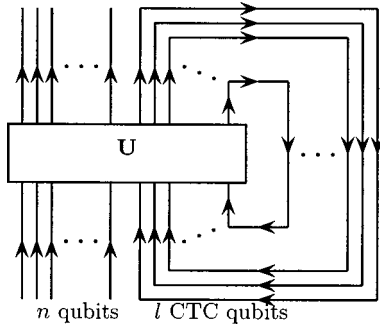

FIG. 1. Pseudospacetime diagram depicting quantum evolution in the presence of qubits which traverse closed timelike curves. The arrows indicate the forward direction of time for each individual qubit. The n qubits on the left are the chronology respecting qubits and the l qubits on the right are the qubits which traverse closed timelike curves. The above diagram is not a real spacetime diagram, but is instead a schematic describing the temporal evolution of the involved qubits. That quantum circuits in general spacetimes can be brought to this schematic form is argued by Deutsch [16].

the density matrix of the CTC qubits at the temporal origin as defined above. In order to avoid logical inconsistency of quantum theory, one must invoke the principle of self-consistency: the state of the CTC qubits at the temporal origin should be the same as these same qubits after the evolution U . Mathematically, we have

$$\rho = \text{Tr}_A[U(\rho_{in} \otimes \rho)U^\dagger], \quad (1)$$

where Tr_A represents the trace over \mathcal{H}_A . Deutsch [16] demonstrated that there is always at least one solution ρ to this self-consistency equation. What to do with multiple self-consistent solutions is discussed below. Given a self-consistent evolution of the CTC qubits, the output of the quantum circuit will be given by

$$\rho_{out} = \text{Tr}_B[U(\rho_{in} \otimes \rho)U^\dagger], \quad (2)$$

where ρ is a solution to Eq. (1). Notice that the evolution from ρ_{in} to ρ_{out} is possibly nonlinear due to the consistency condition: the self-consistent solution to Eq. (1) determines ρ which in turn determines the final mapping, Eq. (2).

Returning now to our assumptions we first discuss a problem previously unaddressed in the literature [16,20,21]. Above we have assumed that there is a temporal origin of the CTC evolution defined by the first interaction between the CTC qubits and the chronology respecting qubits (who have a unique time ordering). Now suppose that a gate $U = (\mathbf{I} \otimes \mathbf{V})U_0$ applied to this system. The consistency condition is then

$$\rho = \text{Tr}_A[(\mathbf{I} \otimes \mathbf{V})U_0(\rho_{in} \otimes \rho)U_0^\dagger(\mathbf{I} \otimes \mathbf{V}^\dagger)]. \quad (3)$$

The temporal origin we have chosen for this consistency condition is now seen to be arbitrary in the following sense. Express \mathbf{V} as a product of two evolutions $\mathbf{V} = \mathbf{V}_2\mathbf{V}_1$. The consistency condition is

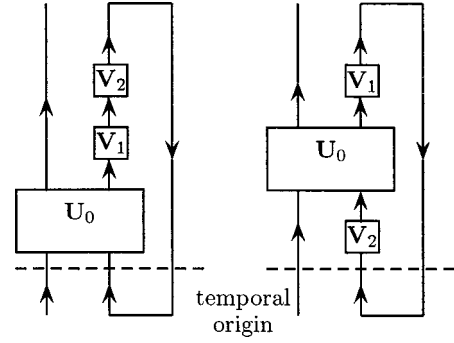

FIG. 2. The temporal origin problem. While there is a notion of the time at which the CTC data first interact with the chronology respecting data, for evolution entirely acting on the CTC qubits before this time, there are multiple ways to choose the temporal origin. Here we show this ambiguity graphically with the dashed line representing the time at which the consistency equation is applied. As shown in the text, this temporal origin ambiguity does not give rise to contradictions in the self consistency condition, Eq. (1).

$$\rho_1 = \text{Tr}_A[(\mathbf{I} \otimes \mathbf{V}_2\mathbf{V}_1)U_0(\rho_{in} \otimes \rho_1)U_0^\dagger(\mathbf{I} \otimes \mathbf{V}_1^\dagger\mathbf{V}_2^\dagger)]. \quad (4)$$

However, there is no reason that the temporal origin should not be after \mathbf{V}_1 is applied such that the consistency condition is really

$$\rho_2 = \text{Tr}_A[(\mathbf{I} \otimes \mathbf{V}_1)U_0(\mathbf{I} \otimes \mathbf{V}_2)(\rho_{in} \otimes \rho_2)(\mathbf{I} \otimes \mathbf{V}_2^\dagger)U_0^\dagger(\mathbf{I} \otimes \mathbf{V}_1^\dagger)]. \quad (5)$$

Via Deutsch's result, there are always self-consistent solutions to each of these different consistency conditions. However, in general these self-consistent solutions may be different and even more disturbing is that these different representations of the same physical process may lead to a different map between ρ_{in} and ρ_{out} . This, however, is not the case. The two self-consistent solutions are related via a change of basis $\rho_2 = \mathbf{V}_2^\dagger\rho_1\mathbf{V}_2$: the superoperator on the non-CTC qubits is therefore the same superoperator. Furthermore, the input-output relationship is unaffected by a change of basis of the CTC qubits due to the cyclic nature of the trace in Eq. (2). Therefore, while the choice of a temporal origin is arbitrary up to the temporal ordering dictated by the chronology respecting system, every choice of a temporal origin results in the same input output relationship for the chronology respecting qubits (see Fig. 2).

Next we turn to the assumption of an initially tensor product state $\rho_{in} \otimes \rho$. Politzer [21] has argued that this assumption is not the most general assumption. The most general initial state which produces the correct input state is one which satisfies $\rho_{in} = \text{Tr}_B[\rho_0]$ where ρ_0 is the initial state of both the chronology respecting and CTC systems. Politzer argues that it is wrong to assume that the state is initially a tensor product because the CTC system has interacted with the chronology respecting system in the CTC system's past at any given event along the CTC qubits history. This withstanding, we note that there is always a factorizable self-consistent solution [16]. Thus, if nonfactorizable solutions are also allowed, the difference between these two must be in the initial value problem of the full chronology respecting plus CTC qubits.

Thus the model we consider, with factorizable inputs, is at least as powerful as the nonfactorizable model of Politzer.

A. Example of the consistency requirement

Consider the evolution of two qubits, the first chronology respecting and the second traversing a CTC under a controlled-phase gate followed by an exchange of the two qubits: $\mathbf{U} = |00\rangle\langle 00| + |01\rangle\langle 10| + |10\rangle\langle 01| - |11\rangle\langle 11|$ (we use a basis where $|ab\rangle$ is the chronology respecting qubit in state $|a\rangle$ and the CTC qubit in state $|b\rangle$.) The initial state of the system is given by the general input density operator $\rho_{in} = \frac{1}{2}(\mathbf{I} + \vec{n} \cdot \vec{\sigma})$ where \vec{n} is the Bloch vector $|\vec{n}| \leq 1$ and $\vec{\sigma}$ is the three-vector of the Pauli operators σ_i . Similarly, a self-consistent CTC qubit state is $\rho = \frac{1}{2}(\mathbf{I} + \vec{m} \cdot \vec{\sigma})$. The evolution of these qubits under \mathbf{U} results in the consistency conditions, Eq. (1):

$$m_x = n_x n_z, \quad m_y = n_y n_z, \quad m_z = n_z. \quad (6)$$

In this case we see that the density operator of the CTC qubit is unique. The output of the chronology respecting qubit can similarly be calculated and found to be

$$\rho_{out} = \frac{1}{2}(\mathbf{I} + n_z^2 n_x \sigma_x + n_z^2 n_y \sigma_y + n_z \sigma_z). \quad (7)$$

Here we see that the evolution $\rho_{in} \rightarrow \rho_{out}$ depends nonlinearly on the initial density matrix ρ_{in} .

B. Multiple self-consistent evolutions

In the previous example we have seen that there is a unique self-consistent solution for the CTC qubit. This, however, is not generally the case. Consider the evolution of the same two qubits, one chronology respecting and the other traversing a CTC, under a controlled-rotation gate $\mathbf{U} = |00\rangle\langle 00| + |01\rangle\langle 01| + |10\rangle\langle 10| + i|11\rangle\langle 11|$. Again take the initial state of the chronology respecting qubit and the CTC qubit to be $\frac{1}{2}(\mathbf{I} + \vec{n} \cdot \vec{\sigma}) \otimes \frac{1}{2}(\mathbf{I} + \vec{m} \cdot \vec{\sigma})$. In this case the consistency condition, Eq. (1), yields the condition

$$m_x = 0, \quad m_y = 0, \quad m_z = \text{unconstrained if } n_z \neq 1,$$

$$m_x, m_y, m_z = \text{unconstrained if } n_z = 1. \quad (8)$$

Clearly the CTC qubit is unconstrained. One may hope that while the CTC qubits state is unconstrained, this does not affect the observable evolution of the chronology respecting qubit. However, the output density matrix is given by

$$\rho_{out} = \frac{1}{2} \left[\mathbf{I} + \left(n_x \frac{1+m_z}{2} + n_y \frac{-1+m_z}{2} \right) \sigma_x + \left(n_x \frac{1-m_z}{2} + n_y \frac{1+m_z}{2} \right) \sigma_y + n_z \sigma_z \right]. \quad (9)$$

We therefore see that the output of this interaction is dependent on the CTC qubit state.

Deutsch [16] has suggested that the self-consistent CTC density operator should be the chosen such that this density operator maximizes the entropy $-\text{Tr}[\rho \ln \rho]$. We should point

out, however, that this solution to choosing which self-consistent solution may itself be inconsistent: there may be multiple states maximizing the entropy which lead to different input output evolutions of the chronology respecting qubits. Further we note that there is another manner in which this consistency paradox can be alleviated: one can assume that the freedom in the density matrix of the CTC systems is an initial condition freedom. One recalls that there are initial conditions which evolve into the CTC qubit; i.e., the specification of conditions such that the compact region with CTC's is generated. It is not inconsistent to assume that some of the freedom in the initial conditions which produce this CTC qubit are exactly the freedoms in the consistency condition. Such a resolution to the multiple-consistency problem puts the impetus of explaining the ambiguity on an as-yet codified theory of quantum gravity. It is interesting to turn this around and to ask if understanding the conditions for a resolution of the multiple-consistency problem can tell us something about the form of any possible theory of quantum gravity which admits CTC's.

Finally we note that not having a solution to the multiple-self-consistent-evolution problem will not change our result concerning quantum computational complexity in the presence of CTC's. We will not encounter an ambiguity of this form in our results: any solution to the multiple self-consistent evolutions problem is compatible with our results.

IV. EFFICIENT SOLUTIONS TO NP-COMPLETE PROBLEMS USING CLOSED TIMELIKE CURVES

Consider the following important example of a computation involving a single chronology respecting qubit and a single CTC qubit. In this example the unitary evolution of the two qubits is given by $\mathbf{U} = |00\rangle\langle 00| + |10\rangle\langle 01| + |11\rangle\langle 10| + |01\rangle\langle 11|$ which corresponds to the process of a controlled-NOT (controlled by the chronology respecting qubit) followed by swapping the two qubits (this operation is also equivalent to two sequential controlled-NOT gates with alternating control qubits.) Again assuming the initial state to be $\frac{1}{2}(\mathbf{I} + \vec{n} \cdot \vec{\sigma}) \otimes \frac{1}{2}(\mathbf{I} + \vec{m} \cdot \vec{\sigma})$, the evolution of the chronology respecting qubit is unambiguous if $n_x \neq 1$:

$$\rho_{out} = \frac{1}{2}(\mathbf{I} + n_z^2 \sigma_z). \quad (10)$$

Examining this nonlinear evolution we can begin to see the power afforded by the nonlinearity. This map $n_z \rightarrow n_z^2$, when repeated, can lead to an exponential separation of states on the Bloch sphere which could normally not be distinguished. Let S denote this map

$$S \left[\frac{1}{2}(\mathbf{I} + \vec{n} \cdot \vec{\sigma}) \right] = \begin{cases} \frac{1}{2}(\mathbf{I} + n_z^2 \sigma_z) & \text{if } n_x \neq 1, \\ \text{ambiguous} & \text{if } n_x = 1, \end{cases} \quad (11)$$

which is not defined for $n_x = 1$.

The following problem is NP complete.

Satisfaction (SAT). Given a Boolean function $f: \{0,1\}^n \rightarrow \{0,1\}$, specified in conjunctive normal form, does there exist a satisfying assignment $(\exists x | f(x) = 1)$?

In order to efficiently solve this problem we will make use of the following oracle quantum gate acting on $n+1$ qubits:

$$U_f = \sum_{i=0}^{2^n-1} |i\rangle\langle i| \otimes \sigma_x^{f(i)}. \quad (12)$$

This gate can be constructed using only polynomial resources in the size of the satisfaction problem. Without quantifying exactly how many resources are needed to enact this gate, we will simply show that only a polynomial number of queries to this quantum gate can be used in conjunction with S to solve the satisfaction problem.

The algorithm proceeds as follows. First the state $|\psi_0\rangle = [(1/\sqrt{2^n})\sum_{i=0}^{2^n-1}|i\rangle] \otimes |0\rangle$ is prepared and acted upon by U_f . This prepares the state $(1/\sqrt{2^n})\sum_{i=0}^{2^n-1}|i\rangle \otimes |f(i)\rangle$. The reduced density operator of the final qubit is now given by

$$\rho_0 = \frac{1}{2} \left[\mathbf{I} + \left(1 - \frac{s}{2^{n-1}} \right) \sigma_z \right], \quad (13)$$

where s is the number of satisfying solutions to $f(x)=1$. We can assume that $s \neq 2^n$ for, if $s=2^n$, then we could easily solve this case by randomly querying a value of $f(x)$. We therefore wish to distinguish between $s=0$ and $0 < s < 2^n$.

Let γ denote the σ_z component of ρ_0 . Initially this component is $\gamma=1-s/2^{n-1}$. After applying the gate S $p > 1$ times, the component of the σ_z evolves to $\gamma_p = (1-s/2^{n-1})^{2^p}$. Notice, if $s=0$, $\gamma_p=1$, and if $0 < s < 2^n$, then γ_p tends to 0 exponentially fast in p . After performing S p times, one measures the qubit in the σ_z basis. This whole procedure is then repeated q times (for a total of pq queries to U_f). If any of the measurements during these q runs yield $\sigma_z=-1$, then the algorithm outputs that there is a satisfying input. If none of the measurements yield $\sigma_z=-1$, then the algorithm outputs that there is no satisfying input. When there is no satisfying clause, this algorithm will always get the answer correct. When there is a satisfying clause, the algorithm will incorrectly identify this as having no satisfying clause with a probability

$$P_{fail} = \frac{1}{2^q} \left[1 + \left(1 - \frac{s}{2^{n-1}} \right)^{2^p} \right]^q. \quad (14)$$

With p and q polynomials in n the probability of this algorithm failing is therefore exponentially small.

We therefore see that using the nonlinearity provided by the gate S we can amplify the probability in the quantum computer such that NP -complete problems can be efficiently computed. Via the definition of NP -completeness we therefore have shown that any problem in the class NP can be efficiently solved by our algorithm.

V. ERROR CORRECTION

While we have demonstrated that an error-free quantum computer can, in the presence of CTC's, solve a hard problem, we do not have a fully convincing argument unless we can argue that the presence of noise or faulty components does not destroy this result. Here we argue that that the pres-

ence of noise in the system will not destroy our result.

Recall from the theory of fault-tolerant quantum computation [4–9] that a quantum circuit containing $p(n)$ gates can be simulated with a probability of error ϵ using $n'(p(n), \epsilon) = O(\text{poly}\{\log[p(n)/\epsilon]\})p(n)$ gates which fail with probability $p < p_{threshold}$ for some fixed $p_{threshold}$. One way to interpret this result is to say that if we want to define our density matrix up to probabilities of outcomes given by ϵ , then we require an error correcting overhead $n'(p(n), \epsilon)$ gates. We would like to use fault-tolerant methods on our construction of S . The simulation of a quantum circuit in fault-tolerant constructions occurs via encoding the quantum information into appropriate error correct code states and by acting with particular operations which fault-tolerantly act on this encoded quantum information. For S constructed above, this means that we need to have both the chronology respecting and the CTC systems evolve with encoded quantum information and for fault-tolerant gates to act on both of these systems. For the chronology respecting qubits we can clearly arrange for the appropriate encoding. For the CTC qubits, however, it is not clear how to arrange for the appropriate encoding to occur. How can we use fault tolerant encoded methods when we cannot reach in to the CTC qubits and perform the appropriate encoding?

Here we sketch a method to overcome this encoding difficulty. To simplify our discussion we will focus on fault-tolerant methods which use the class of stabilizer codes known as Calderbank, Shor, and Steane (CSS) codes [29,30]. These codes are particularly nice for our construction of S because the encoded controlled-NOT operation can be implemented transversely (and hence fault-tolerantly) by a series of controlled-NOT's from the encoded control qubits to the encoded target bits. The first observation which will allow us to perform fault-tolerant methods on the chronology and CTC qubits is to note that the consistency and evolution equations (1) and (2) when considered over the error correcting code space will yield identical evolution and consistency for the encoded quantum information as for the identical unencoded evolution when the fault-tolerant operations preserve the code spaces. The transversal controlled-NOT for the CSS codes preserves the error correcting code spaces. Thus, if in the unencoded evolution the CTC qubits are forced by consistency to be in the state ρ , then for the same encoded evolution, there is a self-consistent solution over the error correcting subspace which corresponds to the encoded version of ρ . The main problem then is that there may be other self-consistent evolutions which involve CTC qubits in states outside of the error correcting code space.

The second observation we need is that there is a degeneracy in stabilizer coding which allows us to consider the full Hilbert space of the CTC qubits as divided into different *equivalent* error correcting code spaces. In particular, the error correcting subspace normally used corresponds to considering the subspace spanned by $+1$ eigenvalue eigenstates of a set of operators known as the generators of the stabilizer group [31]. However, one could equally well work with the subspace spanned by any fixed ± 1 eigenvalue eigenstates of the generators of the stabilizer group. Knowing the ± 1 eigenvalues defines a code space which is of equivalent error correcting capacity as the all $+1$ eigenvalue code space. The

operations which we perform for the ± 1 eigenvalue code space will be different than those if we used the all $+1$ eigenvalue code space, but there is always an equivalent set of operations for this other ± 1 eigenvalue code space. Thus, if we could encode into any one of these ± 1 eigenvalue code spaces, then, via our first observation, we could again guarantee correct encoded evolution. Finally we need the fact that all of the ± 1 code spaces together span the entire space of unencoded qubits.

The three observations above allow us to perform the following procedure on our CTC qubits which effectively allows us to avoid the encoding problem on the CTC qubits. First, we perform fault-tolerant measurements of the stabilizer generators on the CTC qubits which put the result of these measurements in these chronology respecting qubits (as is done fault-tolerantly in [31]). Then, for all further operations, we classically control on this encoded measurement result the appropriate evolution (this needs to be done with a fault-tolerant construction). Thus, the self-consistent evolution will always be the appropriate encoded self-consistent evolution and the evolution will be the proper encoded evolution, but for the CTC qubits over a particular ± 1 eigenvalue code space.

Return now to the issue of using fault tolerance for quantum computation in the presence of CTC qubits. Notice that in our algorithm for efficiently solving NP -complete problems, we need to distinguish the $s=0$ state $\rho(s=0) = \frac{1}{2}(\mathbf{I} + \sigma_z)$ and the $s=1$ state $\rho(s=1) = \frac{1}{2}[\mathbf{I} + (1 - 1/2^{n-1})\sigma_z]$. Since the trace distance [32] between these two states is given by $D(\rho(s=0), \rho(s=1)) = \frac{1}{2}\text{Tr}[|\rho(s=0) - \rho(s=1)|] = 1/2^{n-1}$, then we clearly need to be able to use error correction to maintain at least the probability difference $\epsilon = 1/2^n$. Using standard error correction this can be done using $O(\log[p(n)2^n]p(n)) = O(\log[p(n)]np(n))$ faulty gates (operating below the threshold.) This is simply a polynomial increase in the size of the quantum circuit and therefore does not significantly slow down our CTC algorithm for NP problems.

A slightly more worrisome type of error is as follows. Suppose that in our algorithm the $\rho(s=0)$ state has a component of σ_z which is different than $+1$, $\tilde{\rho}(s=0) = \frac{1}{2}[\mathbf{I} + (1 - \mu)\sigma_z]$, due to some physical noise process. Then, if we apply S p times to this state, it is possible, for large enough μ , that our algorithm will incorrectly identify that the function has a satisfying assignment when, in fact, the function does not. Suppose we run the first phase of our algorithm $p=n$ times. The state $\tilde{\rho}$ will then have a σ_z component of $(1 - \mu)^{2^n}$. Suppose $\mu > b/2^{n^c}$ for some constants b and c for large n . Then, for large n ,

$$(1 - \mu)^{2^n} \geq e^{-2^n/(2^{n^c} + 1)} \geq 1 - \frac{2^n}{2^{n^c} + 1}. \quad (15)$$

If we choose some fixed $c > 1$, then for large n the σ_z component is exponentially close to 1. Therefore repeated applications of S will improperly identify the $s=0$ case with only an exponentially small probability. This implies that we need only protect our system to accuracy $\epsilon = O(1/2^{n^c})$ for some fixed c . This can be done using the threshold theorem using

$O(\log[p(n)]n^c p(n))$ gates, representing a polynomial slowdown, and thus error correction can be used to correct his form of error. While it is true that the nonlinearity we use to solve hard problems exponentially separates quantum states, it appears that we can design quantum error correcting circuits whose noise does not suffer a similar blowup. We have considered only limited errors in this paper, and then only as a sketch as to how more general errors can be dealt with in the presence of nonlinear quantum gates. It remains a challenge bring a fully rigorous treatment of errors in our model to be certain that our model is robust in the presence of noise. We have shown, however, that the problems for which using nonlinearly at first sight appear to be problematic are not problematic and we are thus hopeful that such a full rigorous theory could be developed.

VI. CONCLUSION

Since computation is physical, we need to examine physics in order to form the foundations of a theory of computational complexity. There are two direct ways in which one can go beyond the standard model of quantum computation for which physics might have something new to say about computational complexity. One possible manner to go beyond the standard model would occur if quantum theory needs to be replaced by a more fundamental theory of the evolution of physical systems. For example, proposals for deterministic nonlocal theories [33,34] might offer different computational complexities if the fundamental distinctions which make these models different from quantum theory are accessible. Another example is provided by Hawking's conjecture [35,36] that quantum theory must be modified to solve the information paradox in black hole thermodynamics. The other path beyond the standard model of quantum computation is if the physical theories which are laid on top of quantum theory possess a computational power differing from the current understanding of these theories. For example, it is not entirely clear whether or not current versions of quantum gravity [37] provide physics which is computationally equivalent to the standard model. If the physical theory of gravity is itself to provide a picture of spacetime, how does this modify the theory of computational complexity which is grossly constrained by the geometry of the computer? In this paper we have consider a possible hybrid method which will produce computational complexity which appears to be stronger than the standard model of quantum computation. We have considered that the possible existence of closed timelike curves might follow from a quantum theory of gravity and using the structure uncovered by Deutsch for how quantum theory itself must be modified in the presence of such curves to solve hard computational problems. There are of course many open issues left to be addressed, not the least whether a theory of quantum gravity exists which is compatible with CTC's. However, there are interesting possibilities which might also warrant consideration solely for their theoretical usefulness. For example, in computer science, the difference between space and time complexity is poorly understood [38]. Complexity classes which quantify reasonable amounts of spatial resources ap-

pear to be more powerful than complexity classes which quantify amounts of temporal resources. An obvious reason for this difference lies may be reused while temporal resources only be used once. Clearly, if nature allows CTC's, this obstruction is partially removed. It is interesting to speculate that computational complexity with CTC's can lead to a simplified theory of computational complexity.

We end this paper with the caveat that this work is at best a creature of speculation and currently beyond practical considerations. Without a theory of quantum gravity, we cannot know whether CTC's can exist let alone whether they can be generated within the confines of the such a theory. The surprising answer that quantum computation in the presence of CTC's is a powerful new model of quantum computation:

however, it gives us reason to pursue further understanding of this bizarre model of computation.

ACKNOWLEDGMENTS

We thank Patrick Hayden for bringing to our attention concerns about error correction when using nonlinear quantum evolution. We also acknowledge useful conversations and communications with Todd Brun, Mike Cai, Aaron Denney, David Deutsch, Daniel Gottesman, Julia Kempe, Martin Laforest, John Preskill, and Benjamin Toner. This work was supported in part by the National Science Foundation under Grant No. EIA-0086038 through the Institute for Quantum Information.

-
- [1] P. W. Shor, in *Proceedings of the 35th Annual Symposium on the Foundations of Computer Science*, edited by S. Goldwasser (IEEE Computer Society, Los Alamitos, CA, 1994), pp. 124–134.
 - [2] L. Grover, in *Proceedings of the 28th Annual ACM Symposium on the Theory of Computation* (ACM Press, New York, 1996), pp. 212–219.
 - [3] M. A. Nielsen and I. L. Chuang, *Quantum Computation and Quantum Information* (Cambridge University Press, New York, 2000).
 - [4] D. Aharonov and M. Ben-Or, in *Proceedings of the 29th Annual ACM Symposium on Theory of Computing* (IEEE, Los Alamitos, CA, 1997).
 - [5] D. Gottesman, Phys. Rev. A **57**, 127 (1998).
 - [6] A. Kitaev, in *Quantum Communication, Computing and Measurement* (Plenum Press, New York, 1997), pp. 181–188.
 - [7] E. Knill, R. Laflamme, and W. H. Zurek, Science **279**, 342 (1998).
 - [8] J. Preskill, in *Introduction to Quantum Computation and Information* (World Scientific, Englewood Cliffs, NJ, 1998), pp. 213–269.
 - [9] P. W. Shor, in *Proceedings of the 37th Symposium on the Foundations of Computer Science* (IEEE, Los Alamitos, CA, 1996), pp. 56–65.
 - [10] M. S. Morris, K. S. Thorne, and U. Yurtsever, Phys. Rev. Lett. **61**, 1446 (1988).
 - [11] S. W. Hawking, Phys. Rev. D **46**, 603 (1992).
 - [12] S. W. Kim and K. S. Thorne, Phys. Rev. D **43**, 3929 (1991).
 - [13] S. Deser, R. Jackiw, and G.'t Hooft, Phys. Rev. Lett. **68**, 267 (1992).
 - [14] M. Visser, *Lorentzian Wormholes, From Einstein to Hawking* (Springer-Verlag, New York, 1996).
 - [15] J. L. Friedman, M. S. Morris, I. D. Novikov, F. Echeverria, G. Klinkhammer, K. S. Thorne, and U. Yurtsever, Phys. Rev. D **42**, 1915 (1990).
 - [16] D. Deutsch, Phys. Rev. D **44**, 3197 (1991).
 - [17] J. L. Friedman and M. S. Morris, Phys. Rev. Lett. **66**, 401 (1991).
 - [18] J. B. Hartle, Phys. Rev. D **49**, 6543 (1994).
 - [19] D. S. Goldwirth, M. J. Perry, T. Piran, and K. S. Thorne, Phys. Rev. D **49**, 3951 (1994).
 - [20] H. D. Politzer, Phys. Rev. D **46**, 4470 (1994).
 - [21] H. D. Politzer, Phys. Rev. D **49**, 3981 (1994).
 - [22] M. J. Cassidy, Phys. Rev. D **52**, 5676 (1995).
 - [23] S. W. Hawking, Phys. Rev. D **52**, 5681 (1995).
 - [24] S. W. Hawking and G. F. R. Ellis, *The Large Scale Structure of Spacetime* (Cambridge University Press, Cambridge, England, 1973).
 - [25] T. Brun, e-print gr-qc/0209061.
 - [26] D. S. Abrams and S. Lloyd, Phys. Rev. Lett. **81**, 3992 (1999).
 - [27] A. Vergis, K. Steiglitz, and B. Dickinson, Math. Comput. Simul. **28**, 91 (1986).
 - [28] D. Deutsch, Proc. R. Soc. London, Ser. A **425**, 73 (1989).
 - [29] A. R. Calderbank and P. W. Shor, Phys. Rev. A **54**, 1098 (1996).
 - [30] A. M. Steane, Phys. Rev. Lett. **77**, 793 (1996).
 - [31] D. Gottesman, Ph.D. thesis, California Institute of Technology, Pasadena, CA, 1997.
 - [32] C. A. Fuchs, Ph.D. thesis, The University of New Mexico, Albuquerque, NM, 1996.
 - [33] G.'t Hooft, in *Proceedings of the Eighth International Conference on "Particles, Strings and Cosmology,"* edited by P. Frampton and J. Ng (Rinton Press, Princeton, NJ, 2001), pp. 275–285.
 - [34] L. Smolin, e-print hep-th/0201031.
 - [35] S. W. Hawking, Phys. Rev. D **14**, 2460 (1976).
 - [36] J. Preskill, in *Proceedings of the International Symposium on Black Holes, Membranes, Wormholes, and Superstrings, Woodlands, TX, 1992*, edited by S. Kalara and D. V. Nanopoulos (World Scientific, Houston, TX, 1992), pp. 22–39.
 - [37] L. Smolin, e-print hep-th/0303185.
 - [38] C. M. Papadimitriou, *Computational Complexity* (Addison-Wesley, Menlo Park, CA, 1995).